

FPInnovations
FERIC



Creating forest sector solutions

www.fpinnovations.ca



A Systematic Approach to Increasing the Payload Capacity of Log Trucks Within Existing Regulatory Frameworks

Eric Amlin

Why larger trucks? *"addressing future challenges"*

- **Reduced costs**
- **Reduced fuel consumption**
- **Reduced emissions**
- **Fewer trucks**
- **Relief of driver shortage**

The Process

Impacts on Infrastructure (Bridges/ Pavements)

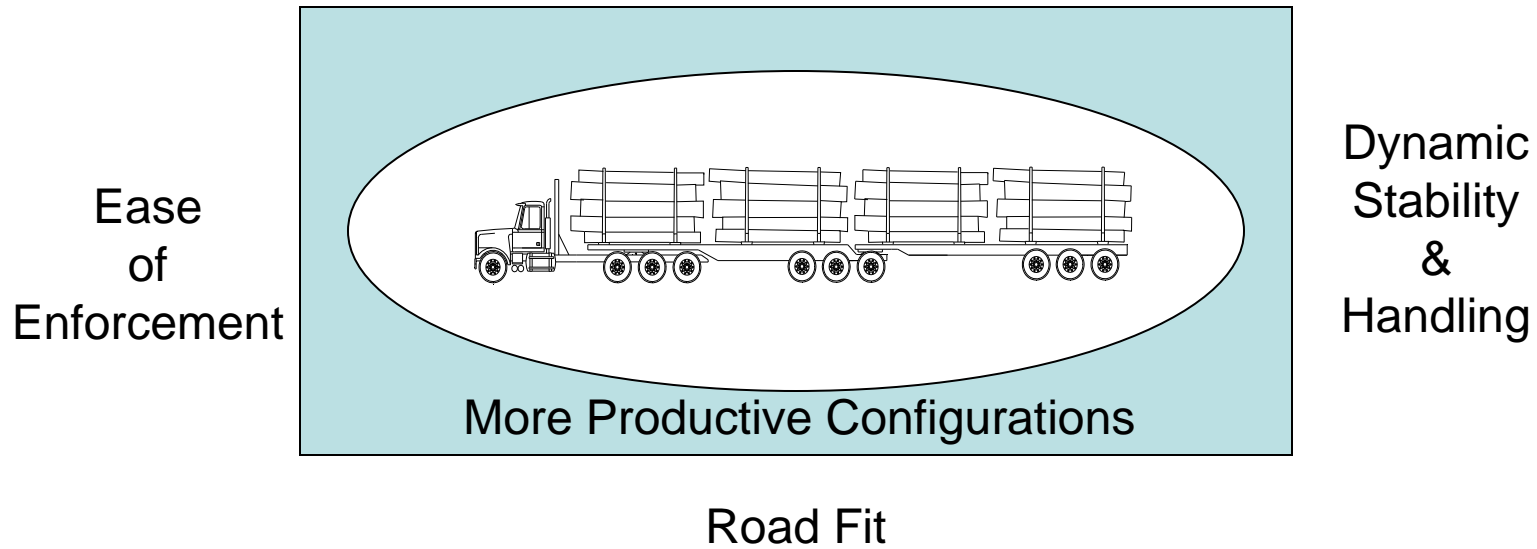

Process Pre-requisites

- **Define the objective (load → truck configuration)**
- **Process acceptance by the regulating agency**
- **Qualified engineering resources (independent)**

The Process

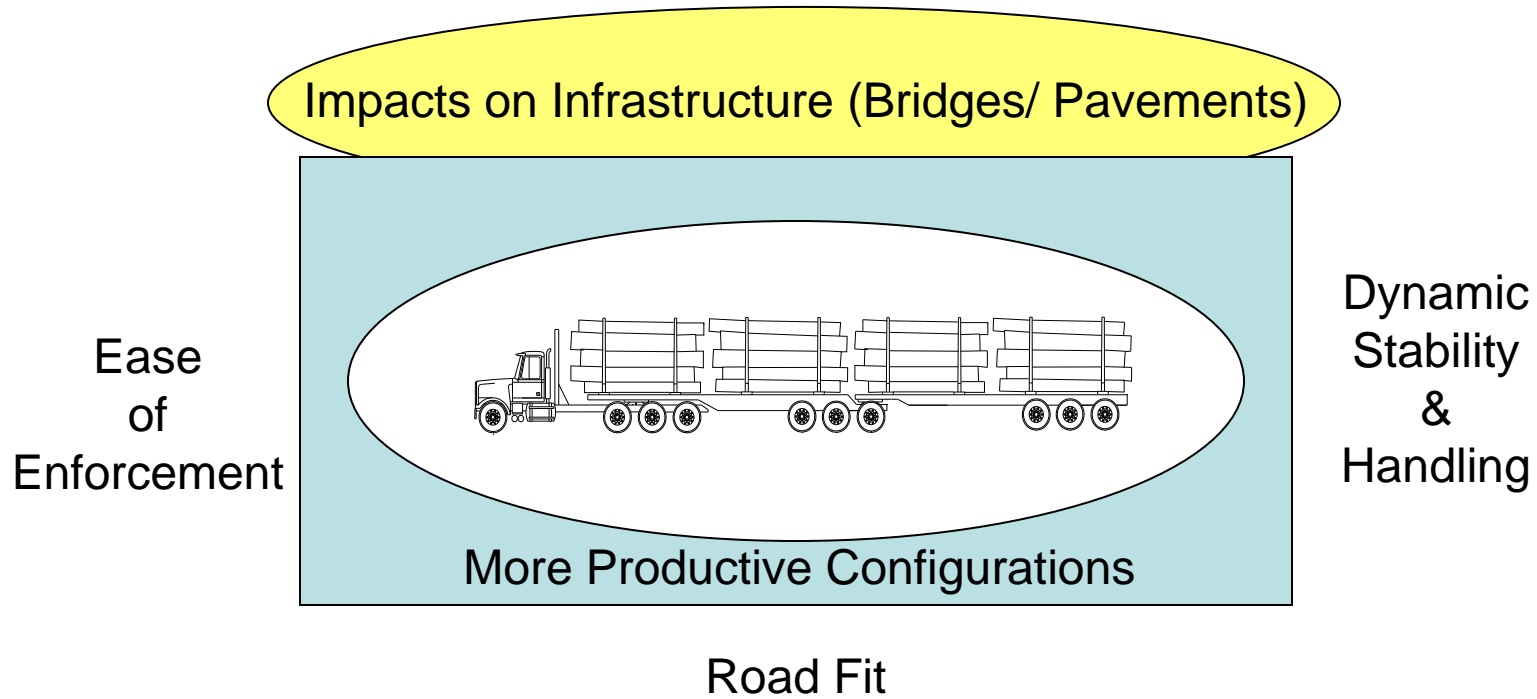

Impacts on Infrastructure: bridges

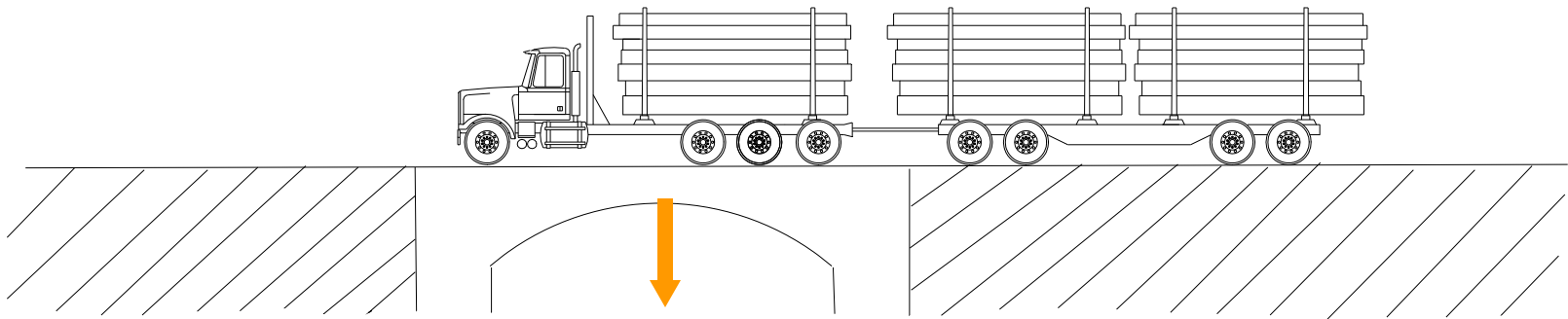

Short-span Structures

Impacts on Infrastructure: bridges

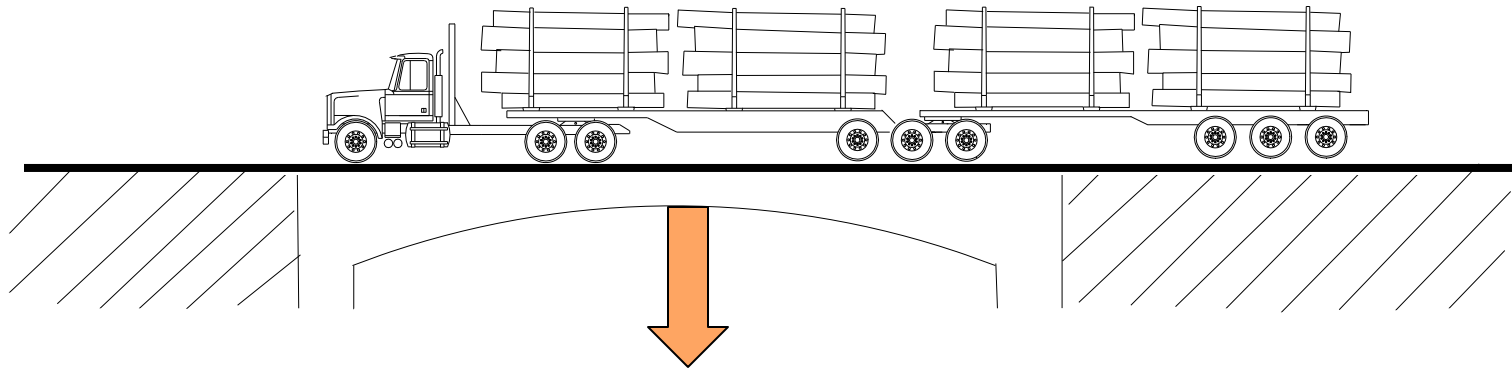

Intermediate-span Structures

Impacts on Infrastructure: bridges

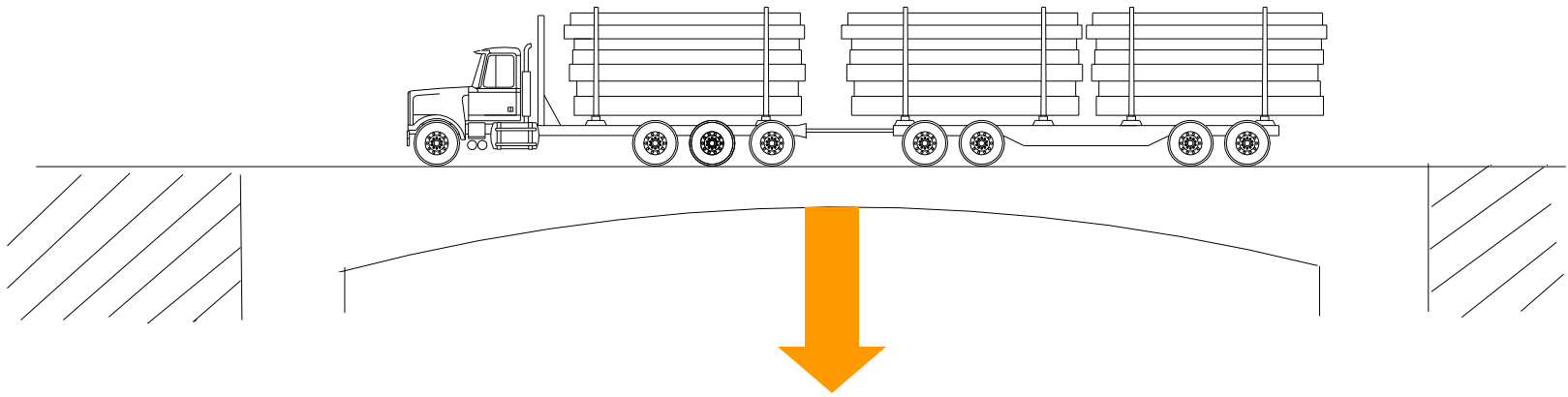

Long-span and Multi-span Structures

Impacts on Infrastructure: pavements

Pavement impact (ESALs) vs mass and axle grouping

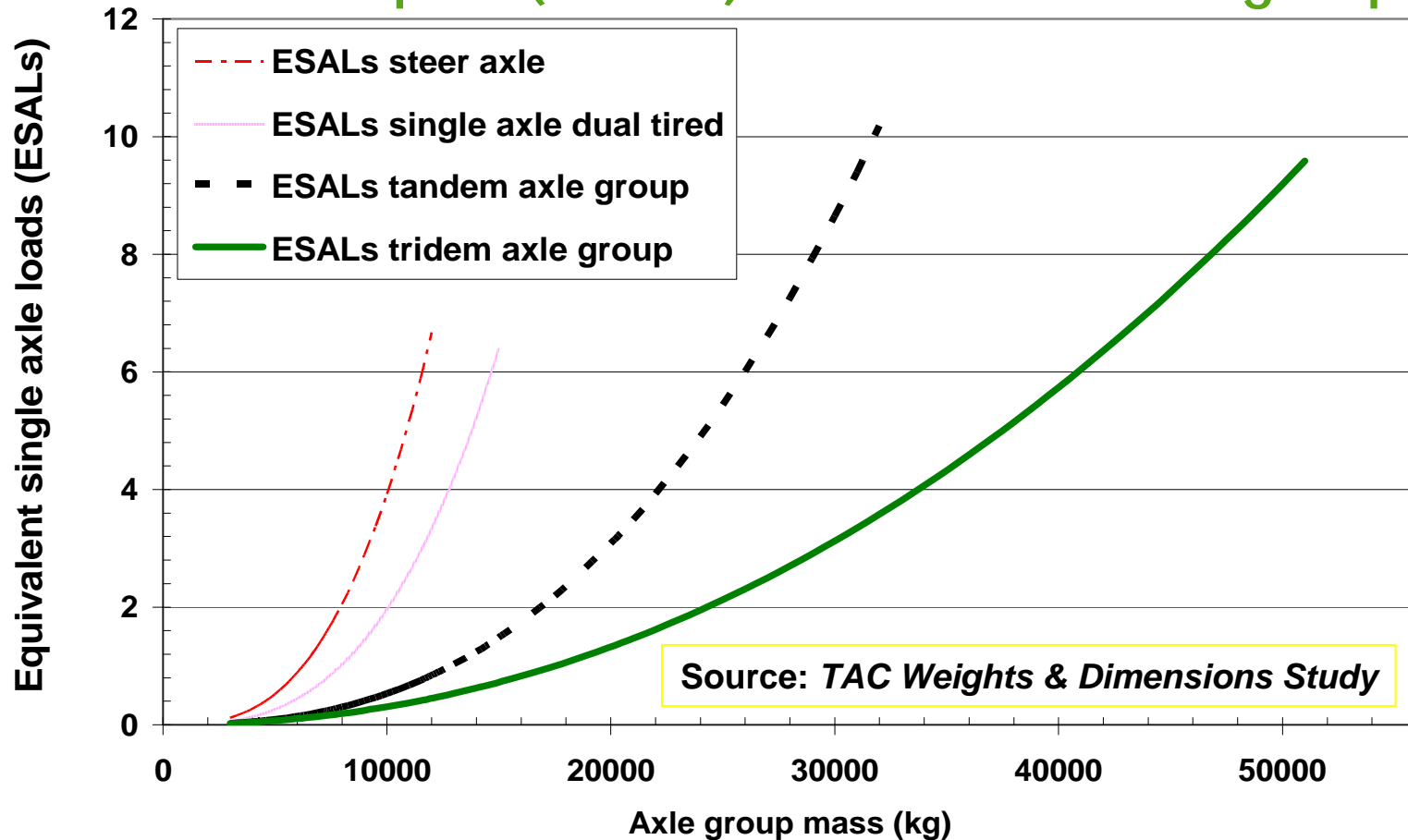

Impacts on Infrastructure: pavements

Overall pavement impact from transport of 100,000 tonnes payload (Alberta, Canada regs)

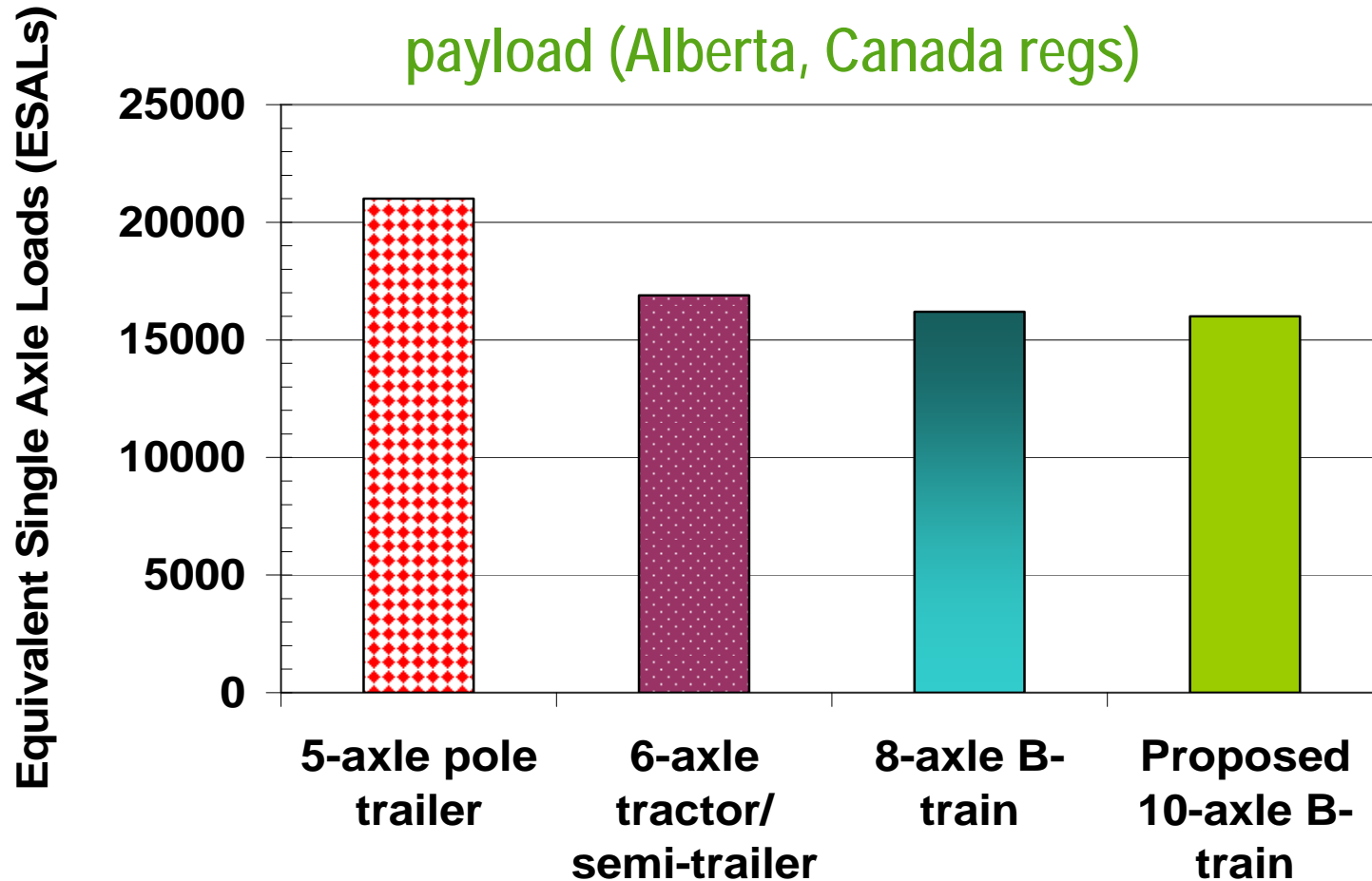

The Process

Impacts on Infrastructure (Bridges/ Pavements)

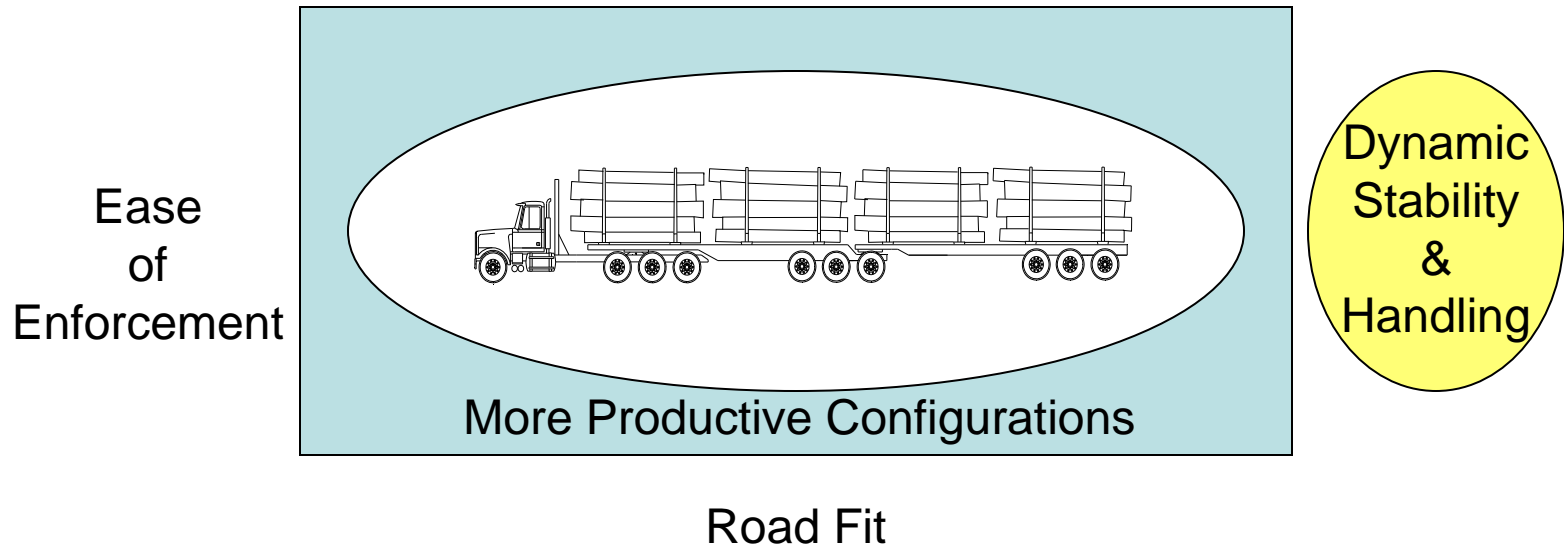

Dynamic Stability & Handling

Stability = resistance to rollover

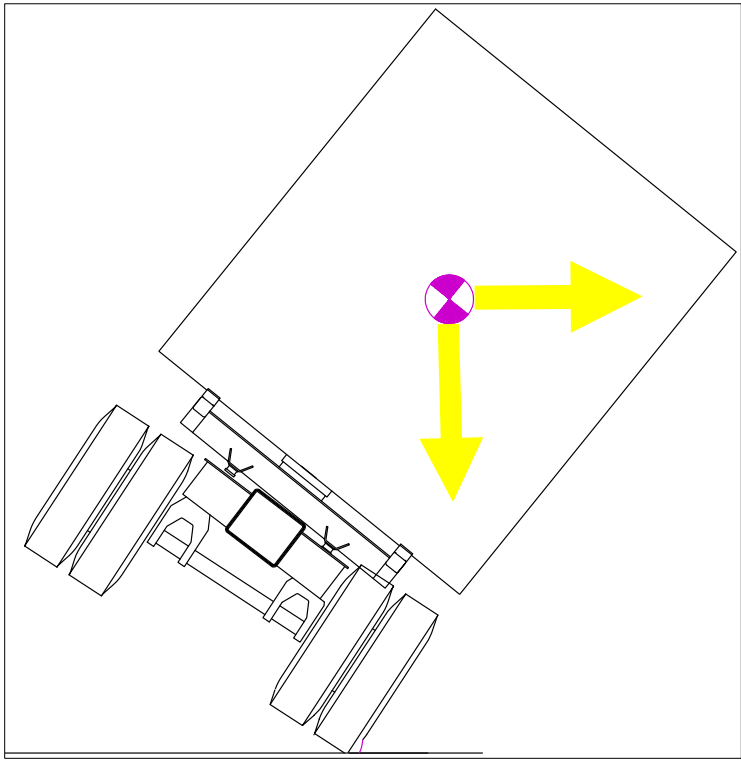

Handling = driver responsiveness

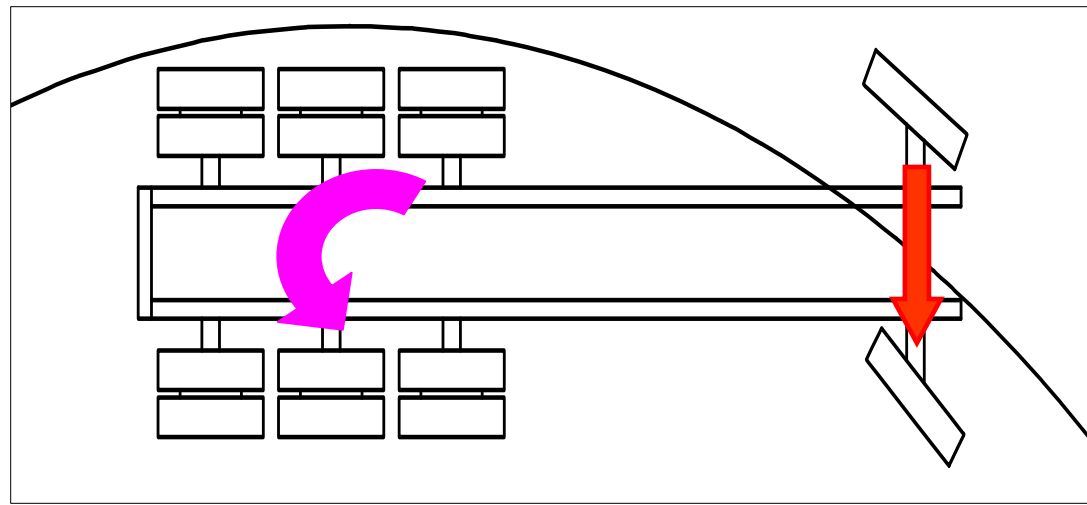

Dynamic Stability & Handling: performance measures

Stability: rollover threshold
rearward amplification
load transfer ratio

Dynamic Stability & Handling: performance measures

Handling: understeer coefficient
friction demand
lateral friction utilization

Dynamic Stability & Handling: modeling & verification



The Process

Impacts on Infrastructure (Bridges/ Pavements)

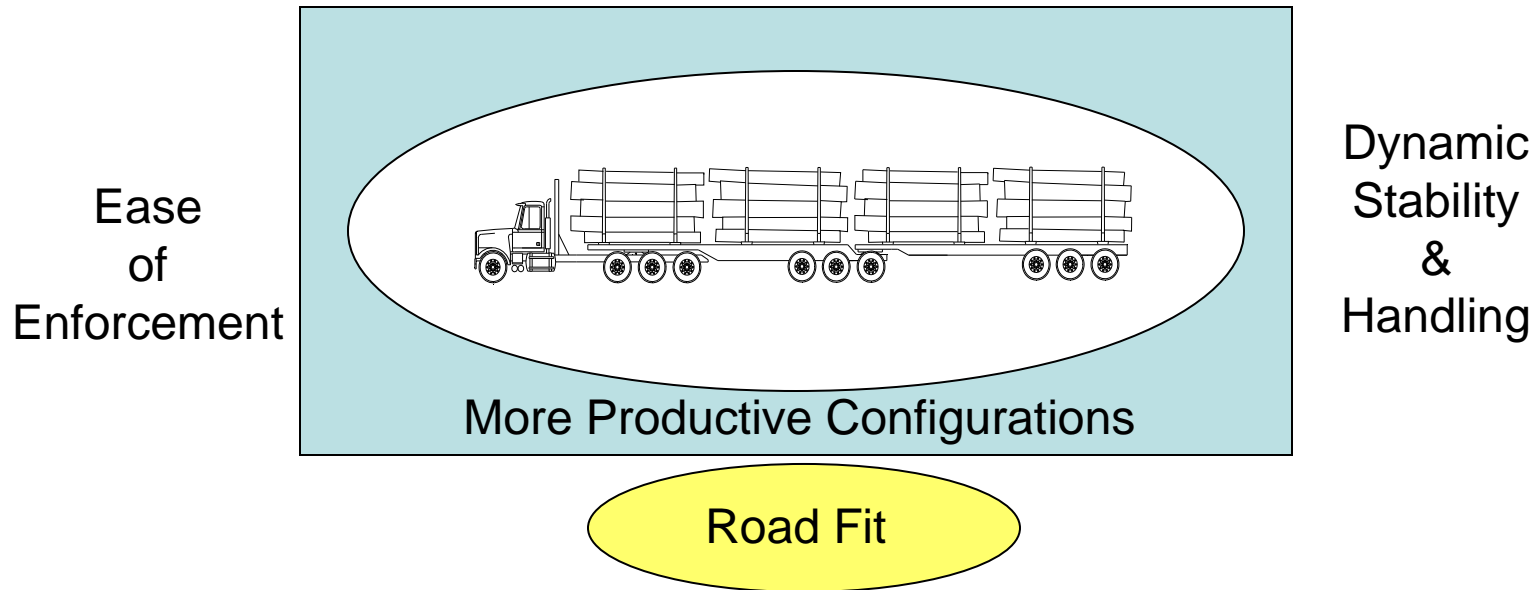

Road Fit: low speed turn off-tracking (LSOT)

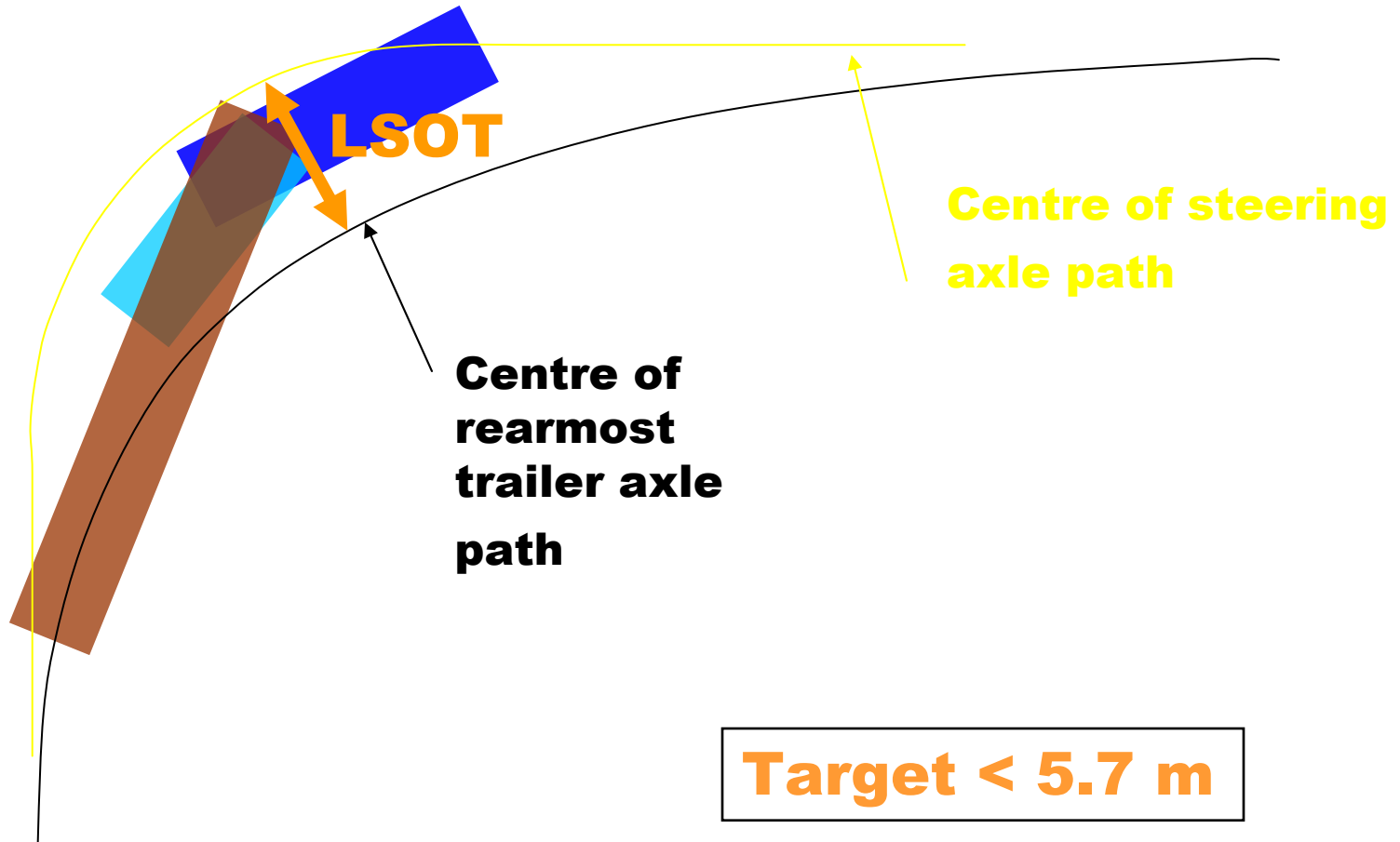

Road Fit: high speed off-tracking (HSOT)

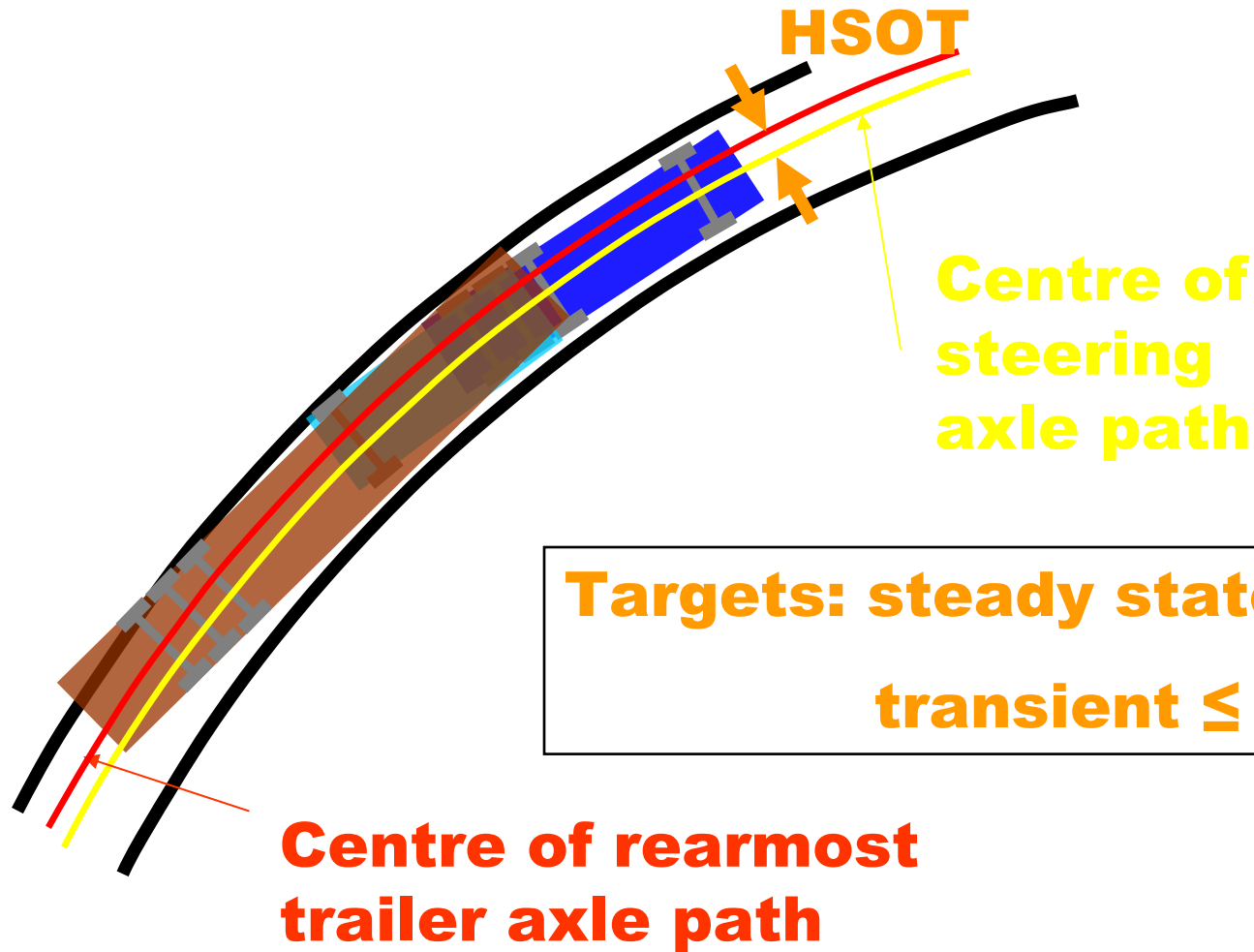

The Process

Impacts on Infrastructure (Bridges/ Pavements)

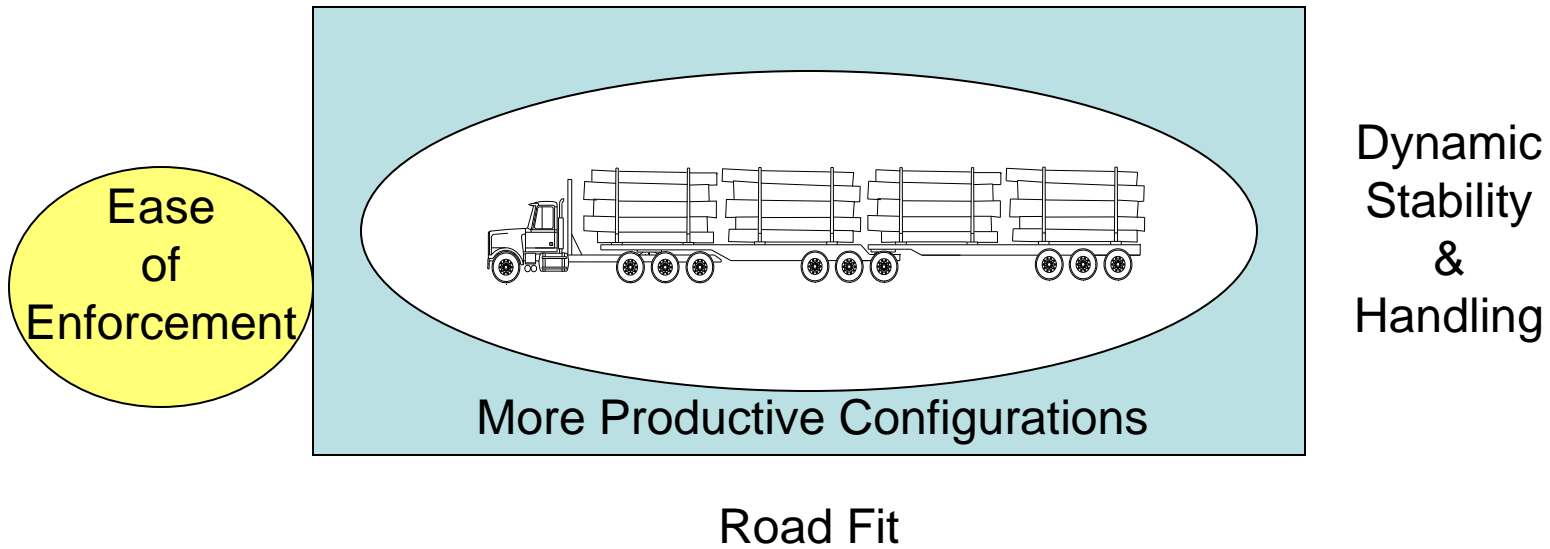

Ease of Enforcement

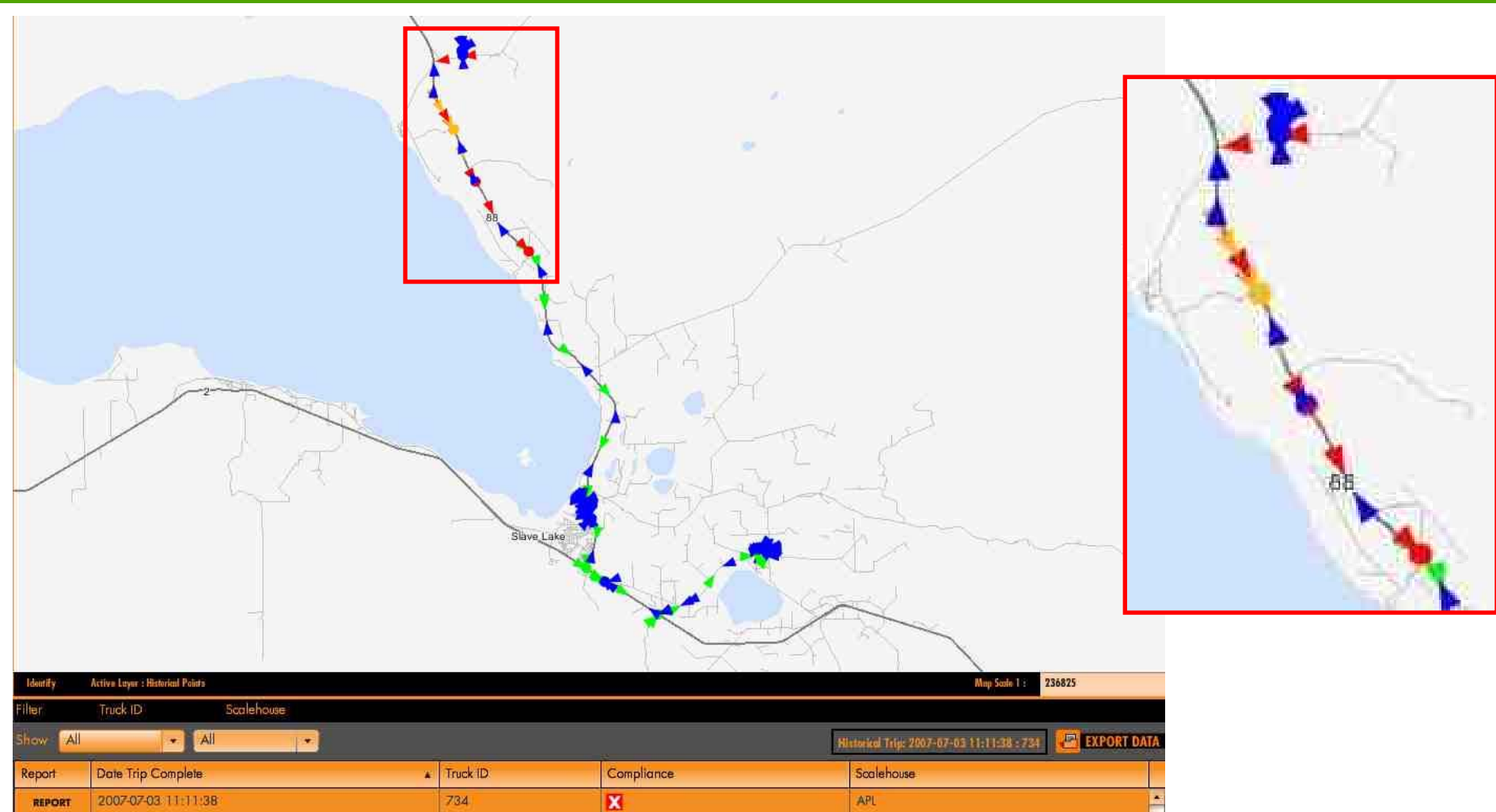

Courtesy: Truckbase Corp.

The Process (and the conflicts)

✓ Impacts on Infrastructure (Bridges/ Pavements)

Ease
of
Enforcement

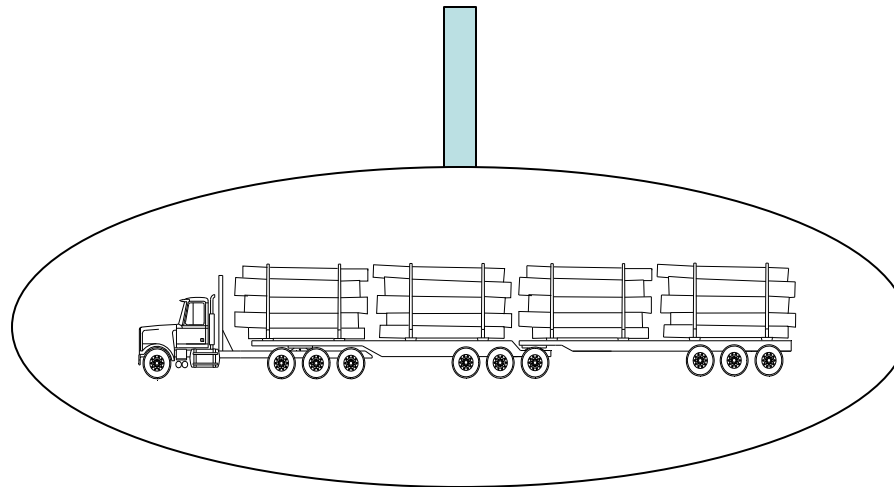

Dynamic
Stability
&
Handling

Road Fit **X**

The Process (and the conflicts)

Impacts on Infrastructure (Bridges/ Pavements)

Ease
of
Enforcement

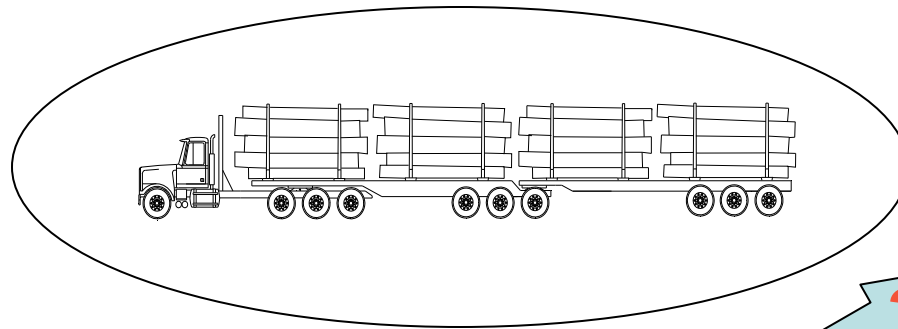

Dynamic
Stability
&
Handling

X

✓ Road Fit

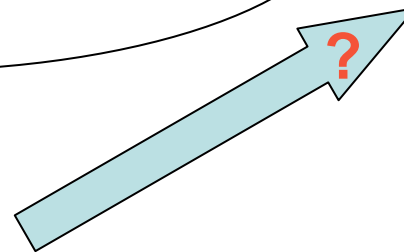

The Process (and the conflicts)

Impacts on Infrastructure (Bridges/ Pavements) **X**

Ease
of
Enforcement



Dynamic
Stability
&
Handling

Road Fit

The Process: some examples of success



